

**2026 IDEERS Rules
for Undergraduate Teams**

IDEERS2026-
V1.0

2026-06-29

1 of 15

The List of Rule Revisions

Version No.	Date	Remarks
V1.0	2026-06-29	First version

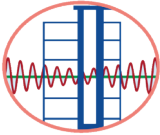
	2026 IDEERS Rules for Undergraduate Teams	IDEERS2026- V1.0
		2026-06-29
		2 of 15

The content presented below serves as the primary rules of this competition. However, if there are cases not stipulated or clearly defined in the rules, the organizer reserves the right of final interpretation of the cases.

1. Overview

Each team is required to design and construct a building model at the competition venue. The model should be able to resist the earthquakes that generated by the shaking table at National Center for Research on Earthquake Engineering (NCEE). This is a two-day competition. On the first day, each team has 5.5 hours (lunch break included) for constructing the building model. All the materials and tools are provided by the organizer. On the second day, all models will be tested on the shaking table at NCEE. The artificial earthquakes with various intensities will be generated by the shaking table. The peak ground acceleration (PGA) will gradually increase to 900 gal (gal = cm/s²).

The theme of this year is “making a tower structure with a single load platform.” Structures with single concentrated load are very common in daily life, such as water tanks, bridge piers, huge T-shaped billboards along highways, telecommunication towers topped with equipment, high towers with observatories, and chimneys with revolving restaurants, etc. Taking water tanks as an example, an elevated large water tank, which stores a huge amount of water with high hydraulic pressure, is generally preferred. Therefore, the maximum base shear and bending moment that the model resists during the shaking table tests are regarded as the capability of the model. In addition, the total weight of the materials used to construct the model is considered as the price of the model. The score of the model is the capability-price ratio, denoted as CP , i.e., $CP = \text{capability}/\text{price}$. A greater value of CP represents a higher score of the model.

2. Team Composition

Each team should consist of four students registered in the same university/college and one instructor who is a teacher at the same school. The instructors are not allowed to construct models using their own hands.

3. Materials and Tools

In addition to the hand tools prepared by participant teams, only the materials and tools provided by the organizer can be used in this competition. Participant teams are allowed to use their own stationery, e.g., pencils, rulers, erasers, and calculators. The service counter will provide some L-shape rulers for computing and marking.

3.1 Materials

The materials provided by the organizer include:

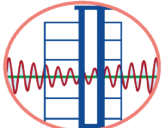
	2026 IDEERS Rules	IDEERS2026- V1.0
	for Undergraduate Teams	2026-06-29
		3 of 15

Item	Quantity	Details
1. Wooden base board	1	It is made of medium density fiberboard (MDF). The size of the board is about 0.55 cm thick, 26 cm (L) × 26 cm (W) (± 0.3 cm).
2. Wooden stick	30	They are made of MDF and are used for constructing the model. Each stick is 70 ± 0.5 cm long with a $5.5 \text{ mm} \times 4 \text{ mm}$ (± 1 mm) rectangular cross section.
3. Hot-melt glue stick	20	Each stick is about 30 cm long and 6 mm in diameter. These glue sticks cannot be used as the members of the building model.
4. Rubber band	16	Each rubber band is 3 mm wide, 1.5 mm thick, and the perimeter is about 240 mm.
5. A4-size paper	12	12 sheets of A4-size paper
6. String	1	A cotton string with 4 m long
7. Bamboo stick	1	This material is used for making the team flag.

3.2 Tools

As shown in Fig. 1, the tools provided by the organizer include:

Item	Quantity	Details
1. Fixing plate	1	This plate is used for fixing the models onto the shaking table as well as for checking the building area.
2. Scissors	1	A general office scissors
3. Wire saw	1	0.9 cm wide and 30 cm long
4. Tape measure	1	The total length is 5.5 m.
5. Manual drill	1	Its bit is 8 mm.
6. Hot-melt glue gun	1	It is a general hot-melt glue gun
7. Large utility knife	2	The width of the blade is about 1.8 cm.
8. Pencil	1	It is a general office pencil.
9. Pencil sharpener	1	It is for sharpening the pencils.
10. Protractor	1	It is a general office plastic semicircular protractor.
11. Marker pen	1	It is a general office marker pen.
12. Ruler	1	A 30 cm long plastic straight ruler
13. Cotton gloves	2	The participants can wear the cotton gloves to avoid burns when using the hot-melt glue gun.
14. Hammer	1	A small hammer
15. File	1	A small file
16. Glue stick	1	A glue stick
17. Cutting mat	1	A3 size

Every team should check the provided materials and tools according to Tables 3.1 and 3.2, respectively, before constructing the building model. If there are broken tools or shortages of materials, please inform the responsible judge immediately. Besides the tools provided by the organizer, participant teams are allowed to take their own hand tools, e.g., gardening shears, chisels, cutting pads, bits with various sizes, etc. Nevertheless, electric tools are forbidden to take and use.

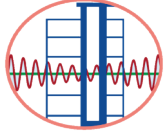

2026 IDEERS Rules for Undergraduate Teams

IDEERS2026-
V1.0

2026-06-29

4 of 15

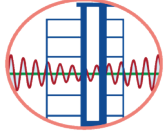

Figure 1. Tools provided by the organizer

4. Requirements for Structures

All teams are encouraged to exert their creativity on constructing the model. Nevertheless, the building models have to meet the below requirements:

Item	Description
4.1 Basic Requirements	<p>4.1.1 Each team has 5.5 hours in total for constructing their building model.</p> <p>4.1.2 The structural components should be composed of the materials provided by the organizer. For example, the structural components can combine with a single wooden stick, multiple wooden sticks, strings, rubber bands and papers.</p> <p>4.1.3 Models must be constructed on the base board (26 cm × 26 cm × 0.55 cm) provided by the organizer. A 3 cm clearance around the edges of the base board must be kept in order to fix the model onto the shaking table.</p> <p>4.1.4 There is only a load platform for each model. The number of mass blocks is from 12 to 24, and two layers of mass blocks are the maximum limit.</p> <p>4.1.5 The vertical projection of the entire model and mass blocks must be located in the 20 cm × 20 cm central area of the base board (i.e., the area enclosed by the dashed lines shown in Fig. 2). Any material (hot-melt glue included) must not contact the fourth-quadrant (IV) base board. In addition, the number of the mass blocks completely, not including partially, located on the fourth-quadrant load platform must be not less</p>



2026 IDEERS Rules for Undergraduate Teams

IDEERS2026-
V1.0

2026-06-29

5 of 15

than 1/2 total number of mass blocks.

4.1.6 The load platform is constructed by wooden sticks (or cotton strings, rubber bands, and paper, etc.). If there are any structural components erected on the load platform, the height of the structural components are not included into the height of the load platform (shown as Fig. 3 and rule 4.3.6).

4.1.7 The abovementioned fourth-quadrant load platform is the region whose vertical projection is within the 10 cm-by-10 cm fourth-quadrant (IV) base board.

4.1.8 The boundary of the whole load platform and the fourth-quadrant load platform must be marked with wooden sticks or cotton strings.

4.1.9 Seismic isolation design is not allowed.

4.1.10 Adding claddings/decorations to the models for the purpose of aesthetic appearance is allowed.

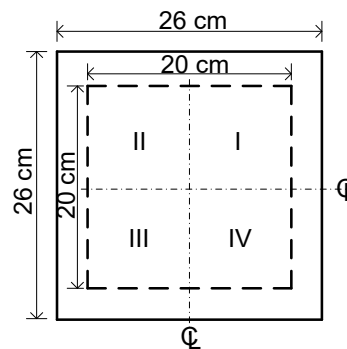

Figure 2. The allowable site area of the model

4.2 Base Board

4.2.1 It is allowed to drill holes on the base board for fixing columns. There is no restriction on the number of columns fixed on the base board.

4.2.2 It is allowed to carry out the measures that enhance the fixity of columns to the base board. Nevertheless, all holes on the base board should be backfilled with hot-melt glue to avoid reducing the weight of the base board.

4.2.3 The base board must be kept flat and integral in case the board cannot be mounted onto the shake table.

4.2.4 No materials (e.g., wooden sticks, cotton strings, rubber bands, etc.) are on the back side of the base board.

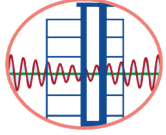

2026 IDEERS Rules for Undergraduate Teams

IDEERS2026-
V1.0

2026-06-29

6 of 15

4.3 Model Height

4.3.1 $H_{min} \leq$ the height of the model that not includes mass blocks, denoted as $H_{model} \leq H_{max}$

4.3.2 $H_{min} \leq$ the height of the load platform, denoted as $H_{platform} \leq H_{max}$

4.3.3 $H_{min} = 50$ cm, $H_{max} = 65$ cm

4.3.4 The height of the model including the mass blocks and team flag must be not greater than 75 cm.

4.3.5 The elevations of two models are sketched as Fig. 3.

4.3.6 All abovementioned model heights are measured from the top of base board, i.e., the thickness of the base board is not included in the model heights. The height of the load platform is the vertical distance between the top of the base board and the lowest point of the surface that the load platform contacts with the mass blocks (Fig. 3).

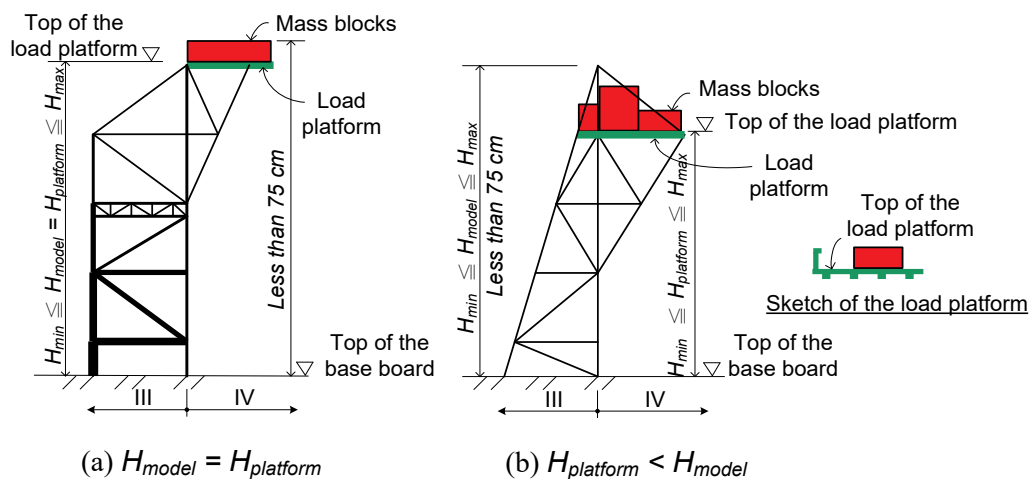

Figure 3. Sketch of the elevations of models

5. Requirements for Mass Blocks

In this competition, mass blocks represent the vertical loading exerted on the load platform. The weight of each mass block is about 635 gram force. The dimension of each mass block is 6.0 cm × 4.5 cm × 3.0 cm (±2 mm). The rules of placing the mass blocks are:

5.1 After the model confirmed by the judges, any changes of the number and the arrangement of the mass blocks are not allowed.

5.2 Mass blocks must be installed on the load platform and not over the boundary of the load platform (Fig. 2).

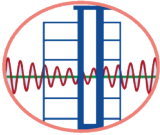
	2026 IDEERS Rules for Undergraduate Teams	IDEERS2026- V1.0
		2026-06-29
		7 of 15

- 5.3 Mass blocks are not installed on the load platform until mounting the model to the shaking table. Only hot-melt glue can be used to fix mass blocks to the load platform. Other materials (e.g., cotton strings, rubber bands and paper etc.) are not permitted to fix mass blocks.
- 5.4 Every team must provide the drawings showing the layout of the mass blocks and the boundary of the load platform within a 20 cm-by-20 cm region of A4-size paper (Appendix 1). It's allowable to use additional blank A4-size papers for related drawings. The layout drawings of mass blocks must clearly indicate the number, the locations, and the directions of the mass blocks. These drawings may include plans, front/side elevations, or 3D perspective drawings, and can be prepared prior to the construction day. Every team must submit their drawings to the responsible judge by 12:00 p.m. (noon) on the construction day.

6. Scoring the Models: Capability-Price Ratio

Scoring the models is based on the capability-price ratio, denoted as CP . A greater value of CP represents a higher rank of the model in the contest.

CP is computed as:

$$CP = \frac{\phi \times Capability}{Price} \quad (1a)$$

where

$$Capability = c_0 \bar{V}_{base} + c_1 \bar{M}_{base} \approx \frac{a_{max} W_{mass} / g}{V_{min}} \left(c_0 + \frac{c_1 H_{platform}}{H_{min}} \right) \quad (1b)$$

$$Price = \frac{W_{model}}{W_0} \quad (1c)$$

$Capability$: Capability of the model

$Price$: Price of the model

ϕ : Reduction (or punished) factor = $1 - 0.02 n_v$ °

n_v : Participant teams must strictly abide the category-I items listed in the model inspection form (Appendix 2). Any violation of the category-I items disqualifies the team from the competition (i.e., $n_v = 50$). n_v is also equal to 50 when other serious violations unanimously identified by judges. In addition, n_v is equal to the total number of violated category-II items listed in the model inspection form (Appendix 2), which may result from the construction error. Participant teams must submit the model inspection form filled with only the team number and the name of department & school before 12 p.m. on the construction day.

\bar{V}_{base} : Normalized base shear

\bar{M}_{base} : Normalized base bending moment

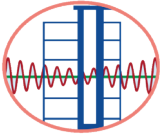
	2026 IDEERS Rules for Undergraduate Teams	IDEERS2026- V1.0
		2026-06-29
		8 of 15

c_0, c_I : weight coefficient, $c_0 = 1, c_I = 50/65$

a_{max} : Maximum ground acceleration successfully resisted by the model (gal)

g : Gravitational acceleration (≈ 980 gal)

W_{mass} : Total weight of mass blocks (N)

V_{min} : Minimum base shear (= 16 N)

$H_{platform}$: The height of the load platform (cm)

H_{min} : Minimum height of the model (= 50 cm)

W_{model} : The model weight that excludes the weight of base board and mass blocks; also refers to the total weight of used materials (gf)

W_0 : The target value for W_{model} (= 320 gf)

7. Mounting Models onto the Shaking Table

- 7.1 Only two members of each team are allowed to mount their model onto the shaking table and fix the mass blocks. This task should be completed within 12 minutes. The team members are responsible for the completion of this task.
- 7.2 The organizer will provide each team with two screwdrivers and screws for mounting the model onto the shaking table.
- 7.3 The organizer will provide each team with a hot-melt glue gun and hot-melt glue for fixing the mass blocks on the load platform of the model.
- 7.4 The materials and tools not provided by the organizer cannot be used to mount the models onto the shaking table and fix the mass blocks.
- 7.5 During the period of mounting the models onto the shaking table and fixing the mass blocks, it is not allowed to strengthen the structure of the model.
- 7.6 The team members mounting the models onto the shaking table should be careful not to touch other teams' models, which have already been mounted on the table.
- 7.7 The side of the base board marked with a sticker is where the model should be built on. In addition, when mounting the model onto the shaking table, the sticker should be on the northwest corner (shown as Fig. 4). If there is any question about the relative positions or directions shown in Fig. 4, please ask the staff or judges for assistance.
- 7.8 The base board is fixed to the shaking table by using a metal plate (Fig. 5). Please note the orientation of the metal plate because the layouts of the holes on the four sides of the metal plate are not the same.

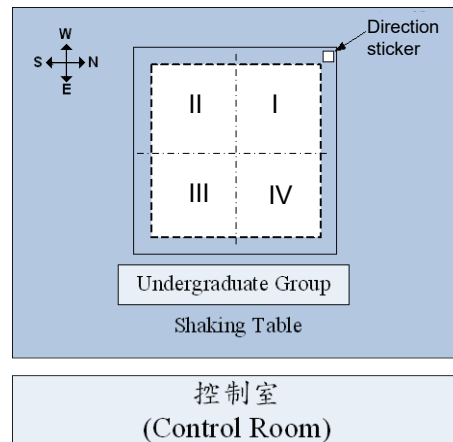

Figure 4. The orientation of the model fixed on the shaking table

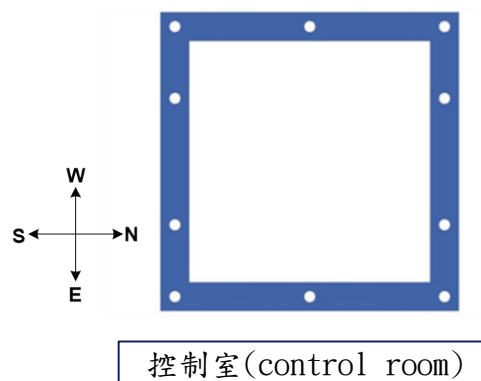
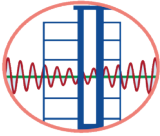

Figure 5. The metal plate for fixing the base board

8. Loading Protocol

All models will be tested simultaneously on the shaking table. The artificial earthquakes generated by the shaking table are broadband excitations, which are bi-directional sinusoidal waves with varied frequencies. The intensity of each artificial earthquake is represented by its peak ground acceleration (PGA).

- 8.1 There will be at most four tests, in which the PGAs are arranged in the sequence of 400 gal, 600 gal, 800 gal, and 900 gal.
- 8.2 The teams whose models pass the test with a PGA of 400 gal will receive the Quake-Resistant Certificate.
- 8.3 The teams whose models pass the test with a PGA of 900 gal will receive the Still Standing Certificate.
- 8.4 Only models that pass the test with a PGA of 600 gal are eligible to calculate the *CP* value for the Seismic Performance Awards ranking.

	2026 IDEERS Rules for Undergraduate Teams	IDEERS2026- V1.0
		2026-06-29
		10 of 15

8.5 The bi-directional time histories of the artificial earthquakes are available on the IDEER's website. All teams are welcome to download these data.

8.6 Figure 6 shows the two components of the displacement time histories of the artificial earthquake with a PGA of 400 gal.

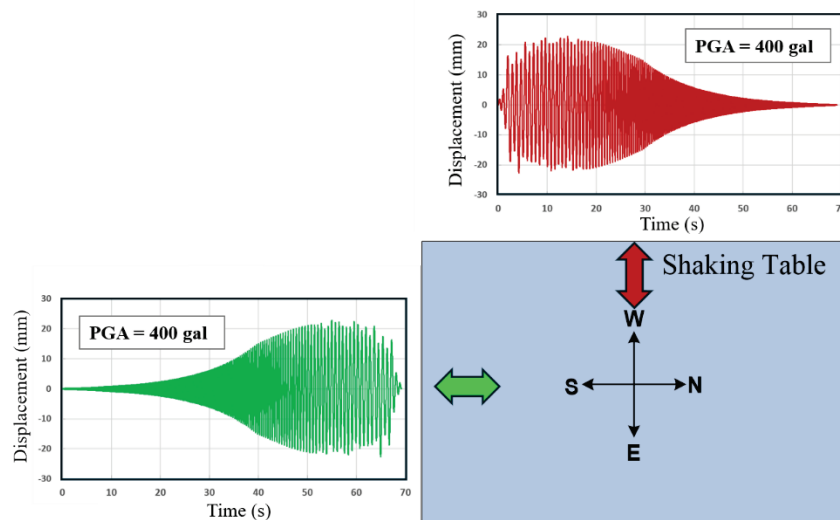

Figure 6. The E-W and N-S components of displacement time histories of the artificial earthquake with the PGA equal to 400 gal

8.7 During the tests, if an event of force majeure or any factor not attributable to the organizer causes damage, displacement, falling, collision, or any other circumstance affecting the test results of a model—such as the collapse of other participating models, or components/mass blocks falling and colliding with the model—the jury may, based on a comprehensive assessment of the on-site situation, determine whether the test results of the model are valid, whether to continue the test, or whether to take other necessary measures. Participating teams shall raise no objection to such determinations.

9. Failure Criteria

A model will be judged as a failure when the following situations occur. The failed model will be removed from the shaking table before the next test.

9.1 The model is collapsed.

9.2 The load platform is unstable or collapsed.

9.3 Any mass blocks fall off, significantly dislocate, sway, or rock.

9.4 The number of columns detached from the base board is greater than or equal to one half of the total number of columns.

9.5 The residual displacement of the inclined model is greater than 10 cm. The residual displacement is the maximum lateral displacement of the model after a shaking event.

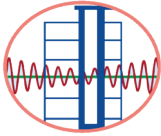
	2026 IDEERS Rules for Undergraduate Teams	IDEERS2026- V1.0
		2026-06-29
		11 of 15

9.6 The base board is obviously loosened during the test.

9.7 The jury has the consensus that a model fails in the test.

10. Exhibition Object

Each team must prepare an exhibition object displaying the design concept and creativity of the model. This exhibition object is done before this two-day competition. The object could be either two-dimensional or three-dimensional. The way of exhibition could be in a static and/or dynamic style. The space for this exhibition is limited to 35 cm (height) × 25 cm (width) × 25 cm (depth) shown as Fig. 7. The design-concept exhibition award is granted based on the clarity and creativity of displaying the design concept of the model through the exhibition object. The affiliation of the team including the department and the university/college must be presented in the exhibition object.

All text on the display exhibits must be written in English, with the exception of the names of the department, university/college, team, and team members. The content must clearly convey the model's design concept, structural features, creative ideas, and seismic resistance concepts. Failure to use English as required, or providing insufficient English descriptions to present the design concept, may result in score deductions by the organizers under the 'Design-concept Exhibition Award' category.

If electronic products are employed in the exhibition object, the team is responsible for the safe keeping of the electronic products. In addition, the team is responsible for the power supply to the electronic products.

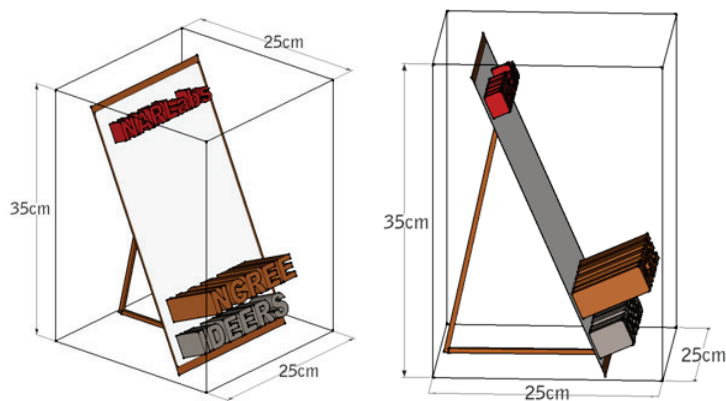
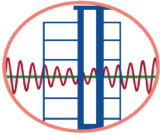

Figure 7. The allowable exhibition space

11. Team Flag

Each team must design a team flag, which is installed on the model during the first day of this contest. This flag may be drawn before or during the contest. All possible shapes of this flag are allowed. Nevertheless, the size of this flag must be not larger than that of a sheet of

	2026 IDEERS Rules for Undergraduate Teams	IDEERS2026- V1.0
		2026-06-29
		12 of 15

A6-size paper (i.e., 14.4 cm length \times 10.5 cm width, or a quarter of an A4-size paper). This flag can be installed on the model by using any provided materials, such as the bamboo sticks.

12. Model Inspection

The period of the model inspection begins at the end of the model construction and ends at the start of the shaking table tests. During the period of the model inspection, jury has the right to change the reduction factor (i.e., ϕ) or require the teams to modify/improve their models if the models violate any competition rules.

12.1 The procedures of the model inspection are as follows:

(1) The host calls the team number. (2) The team members weigh the model. (3) The judges inspect the model and then fill in the inspection form. (4) The staff will take pictures of the model and the exhibition object. (5) Team members must place their model and the exhibition object on the designated table for display and evaluation. (6) Each team sends two representative members to mount the model onto the shaking table for the tests.

12.2 The required items for model inspection are (1) the model, (2) the model inspection form and the drawings showing the layout of mass blocks, and (3) the exhibition object. All the required items are taken to the judges by two members of each team.

12.3 During the two-day competition, if jury has disputes over any models, jury has the right to request the models to be re-examined.

12.4 If a participating team intentionally violates the regulations or maliciously damages another team's model, the jury reserves the right to disqualify the team immediately upon verification.

13. Awards

13.1 Seismic Performance Award:

- Quake-Resistant Certificate: Teams whose models pass the test with a PGA of 400 gal will be awarded an individual certificate for each team member.
- Still Standing Certificate: Teams whose models pass the test with a PGA of 900 gal will be awarded an individual certificate for each team member.
- Gold Award: The team ranked 1st (with the highest *CP* value) will be awarded NT\$20,000, a trophy, and an individual certificate for each team member.
- Silver Award: The team ranked 2nd (with the second-highest *CP* value) will be awarded NT\$15,000, a trophy, and an individual certificate for each team member.
- Bronze Award: The team ranked 3rd (with the third-highest *CP* value) will be awarded NT\$10,000, a trophy, and an individual certificate for each team member.

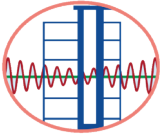
	2026 IDEERS Rules for Undergraduate Teams	IDEERS2026- V1.0
		2026-06-29
		13 of 15

- Merit Award: Teams ranked 4th to 10th in terms of *CP* value will be awarded NT\$2,000 per team and an individual certificate for each team member.

13.2 Structural Design and Innovation Award: The award is granted on the basis of structural design, seismic design concept, and architectural features of models. The jury chooses at most six models for this award. The teams winning this award will be granted NT\$5000/team and a certificate for each team member. The evaluated items and the corresponding percentage of score for this award are:

Item	Percentage	Description
Structural design and seismic design concept	70%	<ul style="list-style-type: none"> ● The arrangement of structural components and the rationality of loading path ● Innovation of seismic design
Architectural features	30%	<ul style="list-style-type: none"> ● Aesthetic of models ● Characteristic of models

13.3 Design-concept Exhibition Award: The award is granted on the basis of the clarity and creativity of displaying/delivering the design concept of the model. The jury chooses at most three exhibition objects for this award. The teams winning this award will be granted NT\$3000/team and a certificate for each team member. The evaluated items and the corresponding percentage of score for this award are:

Item	Percentage	Description
The contents of introducing the design concept	70%	<ul style="list-style-type: none"> ● The clarity and effectiveness of introducing the design concept and structural characteristics
The creativity of the way of displaying the design concept	30%	<ul style="list-style-type: none"> ● The vividness of the way showing the design concept ● The creativity of the way showing the design concept

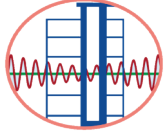

2026 IDEERS Rules for Undergraduate Teams

IDEERS2026-
V1.0

2026-06-29

14 of 15

Appendix 1. Drawing of the layout of the mass blocks.

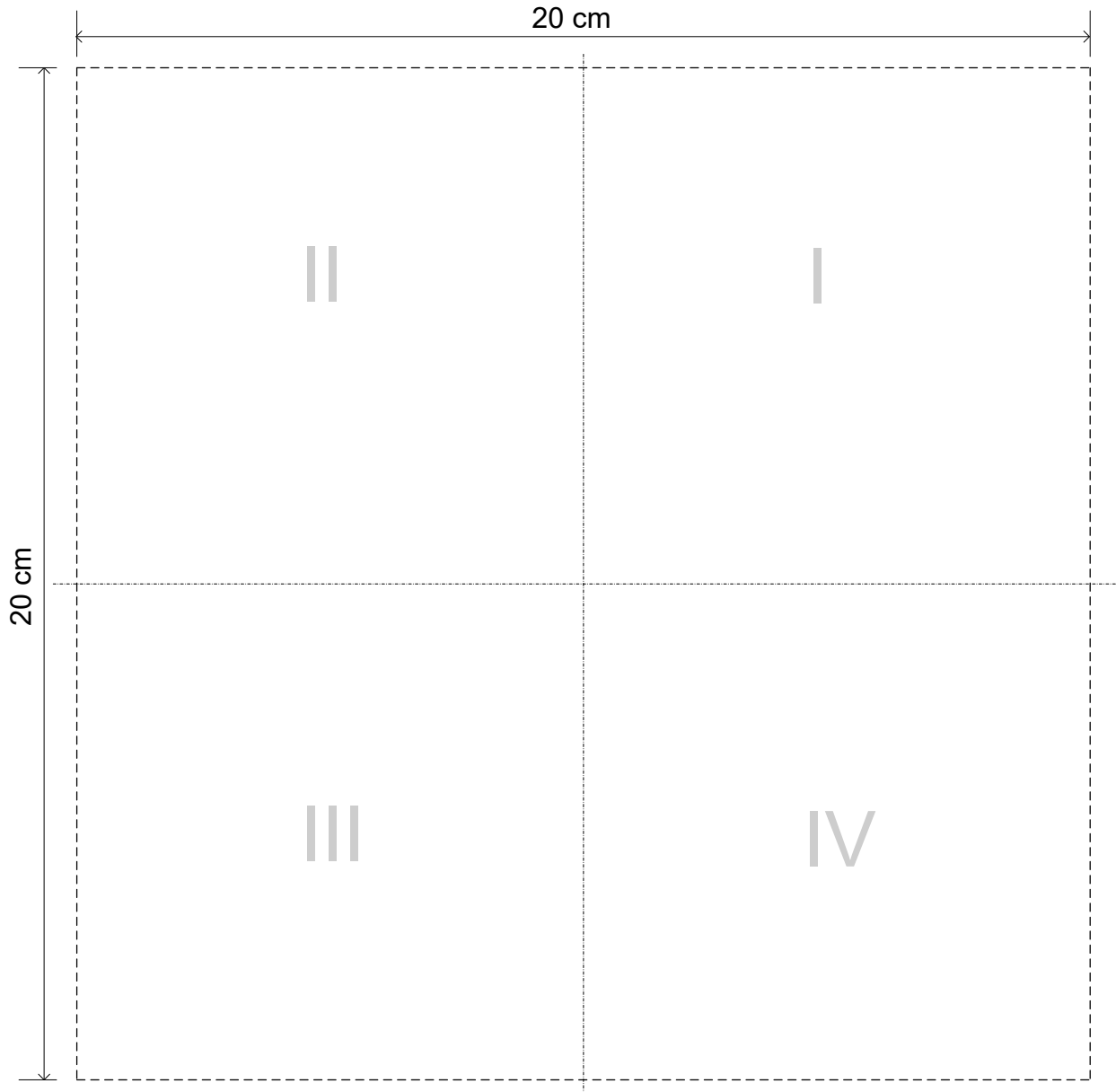

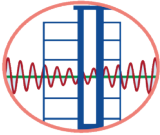
	2026 IDEERS Rules for Undergraduate Teams	IDEERS2026- V1.0
		2026-06-29
		15 of 15

Appendix 2. Model inspection form

Team Number	Department & School		
Weight of model (including base board, but excluding mass blocks) (W_{gross})		gf	Signature of examiner
Weight of base board (W_b)		gf	
$W_{model} = W_{gross} - W_b$		gf	
Number of mass blocks		block	
Height of load platform ($H_{platform}$)		cm	
Work area cleaning (Signature of examiner)		Submission of tools (Signature of examiner)	

Check list	OK	NG
I-1. Only one load platform for placing mass blocks		
I-2. Any material (hot-melt glue included) must not contact the base board of the fourth quadrant		
I-3. Using wooden sticks or cotton strings to mark the boundary of the load platform		
I-4. Using wooden sticks or cotton strings to mark the range of the fourth-quadrant load platform		
I-5. $12 \leq$ number of mass blocks ≤ 24		
I-6. Number of the mass blocks completely located on the fourth-quadrant load platform must be not less than 1/2 total number of mass blocks.		
I-7. No more than 2 layers of mass blocks		
I-8. Submitting the model inspection form and the drawing of mass block layout by 12 p.m. (noon) on the construction day		
I-9. No seismic isolation design		
I-10. No material on the back side of the base board		
I-11. Every hole on the base board must be filled with hot-glue. The base board must keep flat.		
I-12. Cleaning working area and organizing tools in order		
II-1. Keep 3 cm clearance around the edges of the base board		
II-2. The vertical projection of the entire model and mass blocks must be in the 20 cm \times 20 cm central region of the base board		
II-3. $50 \text{ cm} \leq$ the model height that not include mass blocks $\leq 65 \text{ cm}$		
II-4. $50 \text{ cm} \leq$ the height of the load platform $\leq 65 \text{ cm}$		
II-5. The model height including the mass blocks and team flag must be not greater than 75 cm.		

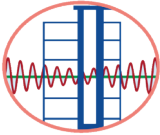
	2026 IDEERS Rules for Undergraduate Teams	IDEERS2026- V1.0
		2026-06-29
		16 of 15

II-6. Mass blocks must be placed on the load platform, and must be not over the boundary of the load platform		
II-7. Not finishing installation of all mass blocks, and still meet the requirement of I-5 & I-6 of the check list		
$n_v =$		

*Category I (I-1~I-12) must be strictly followed. The team would be disqualified from the competition (i.e., $n_v = 50$) if any category-I items are violated.

*Category II (II-1~II-8) is for the possible construction errors. The n_v value is the total number of violated category-II items.