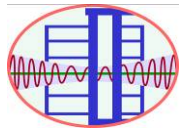
	2014 IDEERS Rules	IDEERS2014-V1
	for Undergraduate Teams	2014-07-16
		1 of 19

The List of Rule Revisions

Version No.	Date	Remarks
V1	2014-07-16	None

	2014 IDEERS Rules for Undergraduate Teams	IDEERS2014-V1
		2014-07-16
		2 of 19

The content presented below serves as the primary rules of this competition. However, if there are cases not stipulated or clearly defined in the rules, the organizer reserves the right of final interpretation of the cases.

1. The overview of this competition

Each team is required to design and construct a building model at the competition venue. The model should be able to resist the earthquakes generated by the shaking table at National Center for Research on Earthquake Engineering (NCREE).

This is a two-day competition. On the first day, each team has 6.5 hours (including a lunch break) for constructing the building model. All the materials and tools are provided by the organizer.

On the second day, all models will be tested on the shaking table at NCREE. The artificial earthquakes with various intensities will be generated by using the shaking table. The peak ground acceleration (PGA) will gradually increase from 250 gal to 800 gal (gal = cm/sec²).

All models are ranked by using the efficiency ratio (ER). The value of ER is computed based on the mass of the model itself, the number of mass blocks supported by the model and the PGA eventually resisted by the model. The winner will be the team whose model obtains the largest value of ER.

In order to increase the challenge and interest of this competition, the theme of this year's competition is "A High First Floor with an Open Space." All teams are encouraged to exert their knowledge and creativity to construct an effective and efficient building model.

2. The composition of team members

Each team consists of four students registered in the same university/college and one instructor, who is a teacher at the same school. During the two-day competition, the instructor is not allowed to use hands on constructing the model.

3. Materials and tools

Only the materials and the tools provided by the organizer can be used in this competition. Stationeries, e.g. pencils, rulers, erasers, and calculators, can be prepared by the teams. Nevertheless, these stationeries can be used only for computing and marking the materials. They cannot be used for cutting and drilling.

	2014 IDEERS Rules	IDEERS2014-V1
	for Undergraduate Teams	2014-07-16
		3 of 19

3.1 Materials

The materials provided by the organizer include:

Item	Quantity	Details
1. Wooden base board	1	It is made of medium density fiberboard (MDF). The size of the board is about 0.55 cm thick, 26 cm (L) × 26 cm (W) (± 0.3 cm).
2. Wooden stick	40	They are made of MDF. They are used for constructing the model and the frame supporting the poster board. Each stick is 70 ± 0.5 cm long with a $5.5 \text{ mm} \times 4 \text{ mm}$ (± 1 mm) rectangular cross section.
3. Hot-melt glue stick	20	Each stick is about 30 cm long and 6 mm in diameter. These glue sticks cannot be used as the members of the building model.
4. Rubber band	16	Each rubber band is 3 mm wide, 1.5 mm thick, and the perimeter is about 240 mm.
5. A4-size paper	12	12 sheets of A4-size paper
6. String	1	A tinted cotton string with 4 m long
7. Bamboo stick	1	This item is used for making the team flag.
8. Poster board	1	The poster is pasted on this board.

3.2 Tools

The tools provided by the organizer include:

Item	Quantity	Details
1. Scissors	1	It is a general office scissors.
2. Wire saw	1	0.9 cm wide and 30 cm long
3. Tape measure	1	The total length is 5.5 m.
4. Manual drill	1	Its bit is 8 mm.
5. Hot-melt glue gun	1	It is a general hot-melt glue gun
6. Large utility knife	2	The width of the blade is about 1.8 cm.
7. Check frame	1	This tool is used for checking the building area.
8. Pencil	1	It is a general official pencil.
9. Pencil sharpener	1	It is for sharpening the pencils.
10. Protractor	1	It is a general official plastic semicircular protractor.
11. Marker pen	1	It is a general official marker pen.
12. Ruler	1	30cm long plastic straight ruler
13. Cotton gloves	2	The participants can wear the cotton gloves to avoid burns when using the hot-melt glue gun.

Before constructing the model, each team should make sure that they have received all the materials and tools list above. If any material/tool is missed or damaged, please report to the judges for assistance.

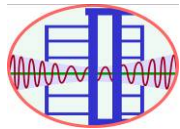
	2014 IDEERS Rules for Undergraduate Teams	IDEERS2014-V1
		2014-07-16
		4 of 19

4. The features of the model

All teams are encouraged to exert their creativity on constructing the model. Nevertheless, the following rules related to the models need to be complied with.:

Item	Details
4.1 Basic structure	<p>4.1.1 All models must follow the common rules of building construction. That is to say, the models are composed of the basic structural components of building structures, e.g., beams, columns, slabs, walls, and bracings.</p> <p>4.1.2 It is not necessary to add claddings/decorations to the models for the purpose of aesthetic appearance. Even if claddings/decorations are added into the model, the clearance requirements stated in section 4.7 should be still met. It should be feasible for the judges to inspect and compute the building area of the model.</p> <div style="text-align: center;">  </div> <p style="text-align: center;">Figure 1. Schematic drawing of the building model.</p>
4.2 Site area of the model	<p>4.2.1 Models must be constructed on the base board (26 cm × 26 cm × 0.55 cm) provided by the organizer. A 3 cm clearance around the edges of the base board must be kept in order to fix the model onto the shaking table. Teams violating this rule will be disqualified or punished by adding penalty weights to the models.</p> <p>4.2.2 The allowable site area is the 20 cm × 20 cm gray square shown in Figure 2. The projection of the entire model onto the base board must be within this gray square.</p>

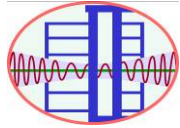

2014 IDEERS Rules for Undergraduate Teams

IDEERS2014-V1

2014-07-16

5 of 19

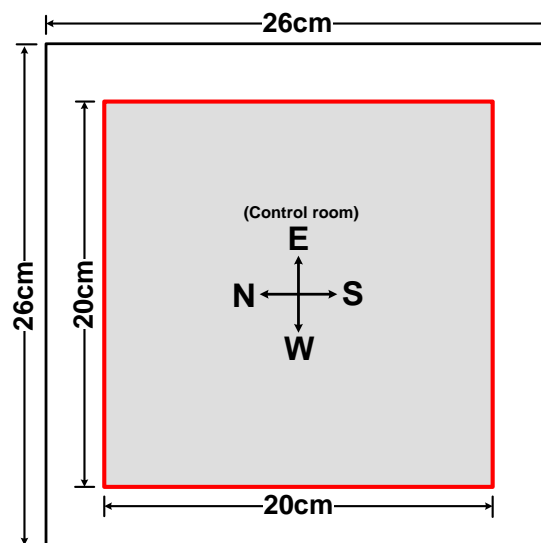
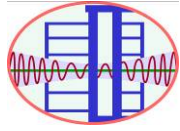

Figure 2. The allowable site area of the model.

<p>4.3 Number of wooden sticks fixed on the base board</p>	<p>4.3.1 Drilled holes are allowable on the base board to firmly hold the wooden stick columns; there is no restriction on the number of wooden sticks that can be fixed on the base board.</p> <p>4.3.2 It is acceptable to implement enhanced fixture of wooden sticks on the base board (e.g., enlarged holes, cotton string running in a ditch, etc.) as long as the enhancement measures (e.g. enlarged holes, ditches, etc.) is backfilled with hot-melt glue to prevent intentional reduction of the base board weight.</p> <p>4.3.3 The base board should be kept integral such that it can be mounted onto the shake table without troubles.</p> <p>4.3.4 All of the wooden stick columns must be fixed on the base board. Isolated system is not allowed.</p>
<p>4.4 Floors</p>	<p>4.4.1 Figure 3 shows the minimum area of each floor. There are at least five complete floors in the model (Figure 3). That is to say, except the first floor (ground floor), there are at least five floors can be loaded with mass blocks.</p> <p>4.4.2 The total height of the model, measured from the top of the base board to the top of the roof, must be not less than 55 cm and not larger than 70 cm.</p> <p>4.4.3 All floors, including the roof but excluding the first floor, will be loaded with mass blocks. The weight factor for the mass blocks on every floor,</p>



2014 IDEERS Rules for Undergraduate Teams

IDEERS2014-V1

2014-07-16

6 of 19

which will be used to compute the ER, is shown in Figure 3.

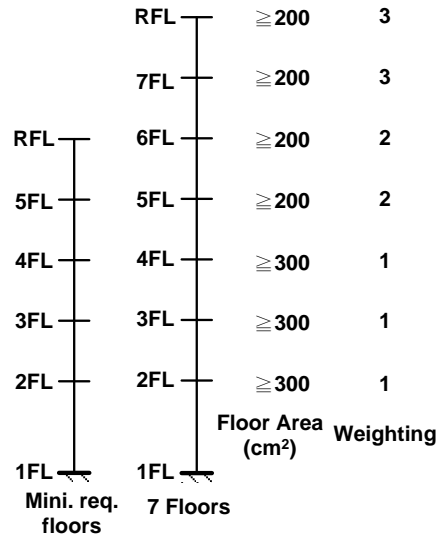

Figure 3. Floor layout.

4.5 Floor area

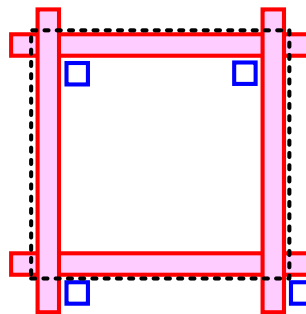

Figure 4. The floor area is the area enclosed by the black dashed lines.

4.5.1 The floor area is defined as the area enclosed by the edge beams. The floor area is measured along the outer edges of the edge beams shown as the black dashed lines in Figure 4. The two ends of the edge beams should be connected to the columns, which are fixed on the base board and are continuous from the ground to the floor. The minimum floor area for each of the 2nd, 3rd and 4th floors is 300 cm². The minimum floor area for each of the other floors is 200 cm². The total floor area, excluding the ground floor, of the model must be between 1400 cm² and 2800 cm². There is no mass block placed on the 1st floor, i.e. the ground floor. The 1st floor area is also not counted in.

4.6 Clear floor height

4.6.1 The clear floor height of the 1st floor is not less than 12 cm.

4.6.2 Except the 1st floor, the clear floor height of each floor is not less than 8

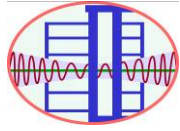

2014 IDEERS Rules for Undergraduate Teams

IDEERS2014-V1

2014-07-16

7 of 19

cm and not larger than 10 cm.

4.6.3 The clear floor height of the i -th floor is defined as the distance between the bottom edge of the lowest beam of the $(i+1)$ -th floor and the top edge of the highest beam of the i -th floor (Figure 5).

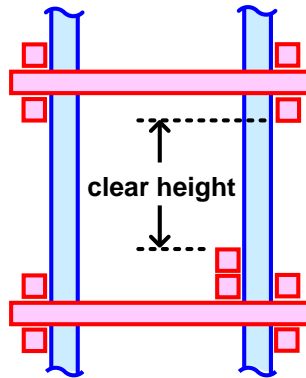

Figure 5. The definition of a clear floor height.

4.7
Exterior
clearance

4.7.1 There are openings for installing doors and windows on every floor of a real building. Therefore, every floor of the model must keep some exterior clearance X_i , in which there is no material/member installed along the perimeter L_i of the floor (Figure 6). The ratio of ΣX_i to ΣL_i for each floor should be no less than a certain value (to be specified later). It should be noted that both of the upward and downward projected lengths of bracings, walls and columns should be considered.

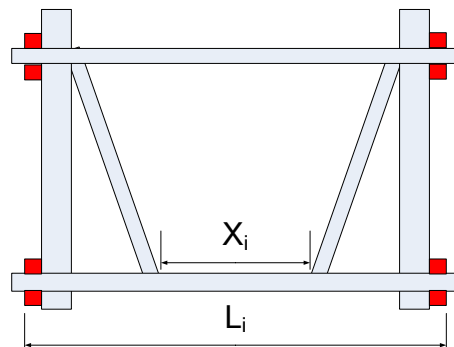

Figure 6

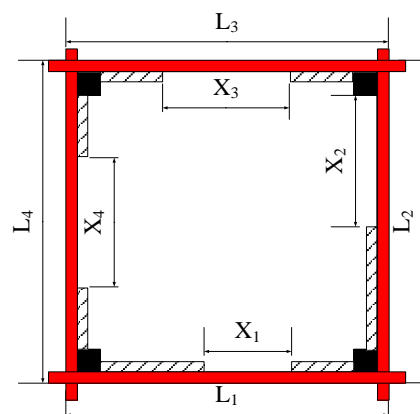
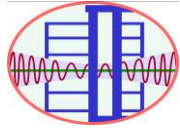

Figure 7

4.7.2 ΣL_i (Figures 6 and 7) is the sum of the floor perimeter defining the floor area shown as Figure 4. ΣX_i is the sum of the parts of the floor perimeter, which are not occupied by the projection of walls, bracings and columns.



4.7.3 The exterior clearance ratio of a floor is defined as:

$$\frac{\sum X_i}{\sum L_i} * 100\% \quad (1)$$

4.7.4 When the elevation of a floor in a certain direction is a trapezoid, L_i is the larger length of the top side and the bottom side. For example, when the bottom side is wider than the top side (Figures 8a and 8b), L_i is the length of the bottom side of the trapezoid. The corresponding X_i is the part of the bottom floor perimeter, which is not occupied by the projection of walls, bracings and inclined columns. On the contrary, when the top side is wider than the bottom side (Figures 9a and 9b), L_i is the length of the top side of the trapezoid. The corresponding X_i is the part of the top floor perimeter, which is not occupied by the projection of walls, bracings and inclined columns.

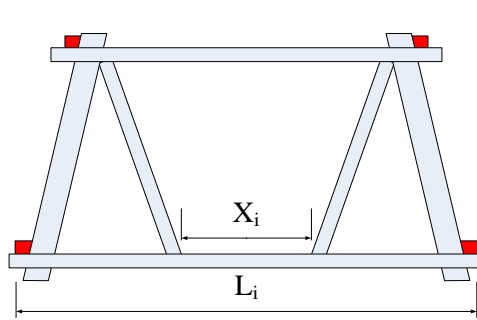

Figure 8a

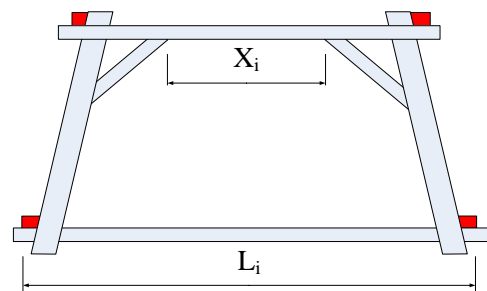

Figure 8b

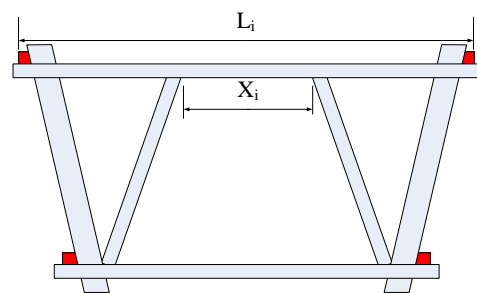

Figure 9a

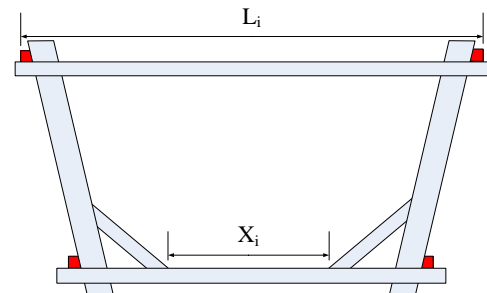
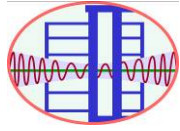

Figure 9b

4.7.5 The space occupied by any materials, e.g., wooden sticks, cotton string, paper, etc., cannot be included into X_i when computing the exterior/interior clearance.

4.7.6 The exterior clearance ratio of each floor ($\sum X_i / \sum L_i * 100\%$), except the 1st floor, must be larger than 45%.



2014 IDEERS Rules for Undergraduate Teams

IDEERS2014-V1

2014-07-16

9 of 19

	<p>4.7.7 In particular, the exterior clearance ratio of the 1st floor must keep the maximum. That is to say, there are no walls, exterior bracings and columns etc., which reduce the exterior clearance, on the 1st floor.</p>
<p>4.8 Interior clearance</p>	<p>4.8.1 In order to keep passages inside a floor, any vertical cross section of a floor must not be fully blockaded. A fully blockaded vertical cross section is the width of the vertical cross section all occupied by the projection of materials/members. The width of the passage is the so-called interior clearance.</p> <div data-bbox="491 658 753 922"></div> <p data-bbox="576 920 703 954">Figure 10</p> <div data-bbox="927 680 1155 909"></div> <p data-bbox="959 931 1082 965">Figure 11</p> <p>4.8.2 The passage should be kept in all directions. That is to say, the vertical cross sections in all directions are not fully blockaded. For example, the projection of Figure 10 is shown as Figure 1. The dashed lines shown in Figure 12 are the passages.</p> <p>4.8.3 When the distance between the end of a vertical member/material and the floor edge is less than 2.5 cm, this member/material is considered as an exterior bracing (Figure 12). An exterior bracing affects only the computation of the exterior clearance rather than the interior clearance.</p> <div data-bbox="561 1370 794 1603"></div> <div data-bbox="944 1352 1177 1639"></div> <p data-bbox="683 1646 1086 1680">Figure 12. An exterior bracing.</p> <p>4.8.4 The interior clearance in any direction must be not less than 5 cm.</p> <p>4.8.5 It should be noted that the interior bracings cannot touch with the mass blocks. The detail explanation of this item is stated in the section 5.</p> <p>4.8.6 In particular, there are no walls, columns and bracings, etc., which reduce the interior space, inside the 1st floor. That is to say, the inside of the 1st floor should keep the maximum.</p>

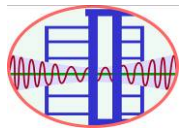
	2014 IDEERS Rules for Undergraduate Teams	IDEERS2014-V1
		2014-07-16
		10 of 19

5. The placement of mass blocks

In reality, buildings are subjected to various types of loading. In this competition, mass blocks are used to simulate the vertical loading occurred in real buildings. The rules of placing the mass blocks are:

5.1 The material of the mass blocks is steel. The dimension of each mass block is 6.0 cm × 4.5 cm × 3.0 cm (±2 mm). The weight of each mass block is about 635 g.

5.2 The average vertical loading on each unit floor area is 10 g/cm². The required number of mass blocks on each floor is computed using Equation (2) and must round half up to the nearest integer.

$$\text{Number of mass blocks} = \text{floor area (cm}^2\text{)} \times 10 / 635 \quad (2)$$

5.3 All models should carry the required number of mass blocks as per Rule 5.2. One may choose to install additional mass blocks in their model in compliance with Rules 5.4 - 5.7. Any violation of the rules shall incur penalty weight as per Rule 5.8.

5.4 Mass blocks may be placed horizontally or vertically on the floors. Nevertheless, mass blocks cannot not be stacked up.

5.5 Mass blocks can be placed on top of beams, but cannot touch columns or bracings. The mass blocks, which touch columns or bracings, are treated as a part of the structure.

5.6 Mass blocks must be placed inside the floor area, i.e., any parts of the mass blocks are not allowed to be beyond the boundary of the floor.

5.7 Mass blocks are placed on the floor when mounting the model to the shaking table. Only hot-melt glue can be used to fix mass blocks to the floors. Other materials, such as paper, cotton string, rubber bands etc., are not permitted to fix mass blocks.

5.8 If any individual mass block installed onto the model floors is found to have one or more of the following conditions, that particular mass block will incur 50 grams of penalty weight, and that mass block shall not be counted into the calculation of Efficiency Ratio.

5.8.1 A mass block extendeds beyond the boundary of a floor by 5 mm or more.

5.8.2 A mass block touches columns, or bracings.

5.8.3 Mass blocks are stacked up vertically.

5.8.4 The actual number of mass blocks installed does not conform to the reviewed Calculation Sheet (either by mistake or failure of implementing compliant installation).

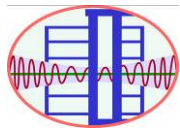
	2014 IDEERS Rules for Undergraduate Teams	IDEERS2014-V1
		2014-07-16
		11 of 19

Example:

Floor No.	Floor Area (cm ²) (A)	Calculated Steel Blocks (B)=(A) × 10 / 635	Minimum Required Steel Blocks (C)	Actual Applied Steel Blocks (D)	Weighting (E)
RFL	200	3.15	3	5	3
7FL	280	4.41	4	6	3
6FL	300	4.72	5	7	2
5FL	360	5.67	6	8	2
4FL	381	6.00	6	8	1
3FL	390	6.14	6	8	1
2FL	400	6.30	6	8	1

6. The grading rules

The criterion used for grading the performance of the models is the efficiency ratio (ER). The ER is computed as:

$$ER(\text{Efficiency Ratio}) = \frac{I \times \sum W_i}{M_M - M_B + M_p} \quad (3)$$

where:

I : The maximum seismic intensity resisted by the model (gal).

$\sum W_i$: The total number of mass blocks supported by the model. In addition, the number of mass blocks on different floors is multiplied by different weight factors (Figure 4). The weight factor for the mass blocks on the 2nd, 3rd and 4th floors is equal to one. The weight factor for the mass blocks on the 5th and 6th floors is two. The weight factor for the mass blocks on the 7th and upper floors is three. It is noted that there is no mass block placed on the 1st floor, i.e. the ground floor.

M_M : The mass of the model itself, which excludes the mass blocks.

M_B : The mass of the base board.

M_P : The penalty mass, which penalizes the violation of the competing rules. The detail of the penalty mass is shown in Table 1.

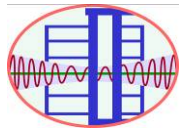
	2014 IDEERS Rules for Undergraduate Teams	IDEERS2014-V1
		2014-07-16
		12 of 19

It indicates that a model resisting larger earthquake load by using less material gets a larger value of ER. The larger the ER is, the better the model's performance is.

Table 1. The penalty mass.

Violations	Penalty mass
1. Clean up the working area and arrange the tools in order	500 g
2. The site area of the model and the clearance along the edge of the base board (≥ 3 cm)	500 g
3. The total height of the model ($55 \text{ cm} \leq H \leq 70 \text{ cm}$)	200 g
4. The total floor area ($1400 \text{ cm}^2 \leq A \leq 2800 \text{ cm}^2$)	100 g
5. The exterior and interior clearances for the 1 st floor	500 g
6. Violation of mass block installation requirements (see Rule 5.8)	50 g /stick
7. The clear floor height(1FL ≥ 12 cm, 8 cm \leq other floors ≤ 10 cm)	50 g / cm
8. Exterior clearance ratio of each floor (except the 1 st floor) $\sum X_i / \sum L_i > 45\%$	10 g / %
9. Interior clearance (must ≥ 5 cm for all floors except 1FL)	100 g / cm
10. Floor area (2-4FL: $> 300 \text{ cm}^2$; 5FL-RFL $> 200 \text{ cm}^2$)	5 g / cm^2

For example, there is a model with the mass of the model itself, M_M , equal to 750 g, and the mass of the base board, M_B , equal to 275 g. In addition, the penalty mass, M_P , is 50 g because the clear height of one floor is only 7.6 cm. There are 8, 8, 8, 8, 7, 6 and 5 mass blocks placed on the 2nd, 3rd, 4th, 5th, 6th, 7th and roof floors, respectively. This model passes the shaking test with a PGA equal to 700 gal, but fails at the subsequent shaking test with a PGA equal to 800 gal. Thus, the efficiency ratio of this model is computed as:

$$ER = \frac{I \cdot \sum W_i}{M_M - M_B + M_P} = \frac{700 \cdot (8 \cdot 1 + 8 \cdot 1 + 8 \cdot 1 + 8 \cdot 2 + 7 \cdot 2 + 6 \cdot 3 + 5 \cdot 3)}{750 - 275 + 50} = 116$$

7. Mounting models onto the shaking table

Before the models are tested on the shaking table, there are periods allowing all teams to mount their models onto the shaking table and fix mass blocks on the floors of models.

7.1 Only two members of each team are allowed to mount their model onto the shaking table and fix the mass blocks. This task should be completed within 15 minutes. The team members are responsible for the completion of this task.

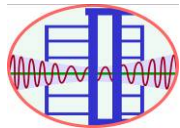
	2014 IDEERS Rules for Undergraduate Teams	IDEERS2014-V1
		2014-07-16
		13 of 19

- 7.2 The organizer will provide a screwdriver and screws to each team for mounting the model onto the shaking table.
- 7.3 The organizer will provide a hot-melt glue gun and hot-melt glue to each team for fixing the mass blocks on the floors of the model.
- 7.4 The materials and tools not provided by the organizer cannot be used to mount the models onto the shaking table and fix the mass blocks.
- 7.5 During the period of mounting the models onto the shaking table and fixing the mass blocks, it is not allowed to strengthen the structure of the model.
- 7.6 The team members mounting the models onto the shaking table should be careful not to touch other teams' models, which have already been mounted on the table.
- 7.7 After all teams completed the task of mounting their models onto the shaking table and fixing the mass blocks, IDEERS staff will check whether or not all models are safely mounted on the shaking table and make necessary reinforcement. Nevertheless, each team is still completely responsible for the fixture of the model and the mass blocks.
- 7.8 The judges will examine all models mounted on the shaking table. The model with the following conditions stated in 7.8.1 to 7.8.3 will be required to make modifications of the model within an allowed time period. Otherwise, a certain penalty will be given to the model by the judges. Sometimes, in the worst case, the team may be disqualified for ranking in this contest.
- 7.8.1 The number of mass blocks on each floor is not consistent with that reported in the check table.
- 7.8.2 Mass blocks are attached to columns/bracings by using hot-melt glue.
- 7.8.3 Mass blocks are beyond the boundary of the corresponding floor.
- 7.9 The side of the base board marked with a sticker is where the model should be built on. In addition, when mounting the model onto the shaking table, the sticker should be on the northwest corner (shown as Figure 13). If there is any question about the relative positions or directions shown in Figure 13, please ask the staffs/judges for assistance.

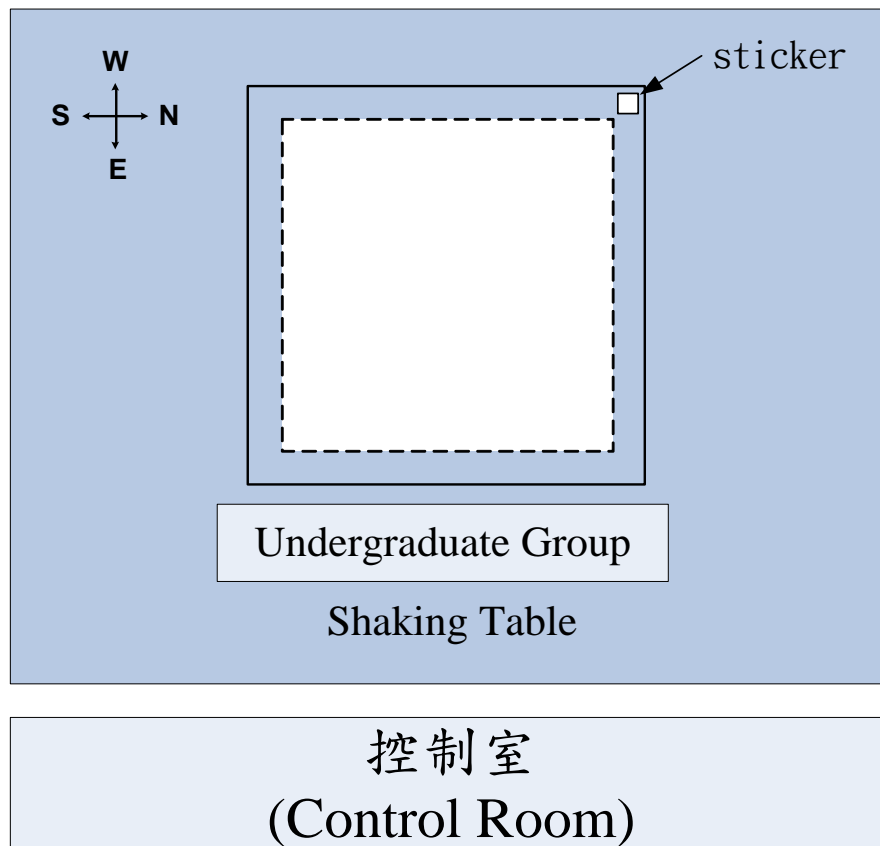
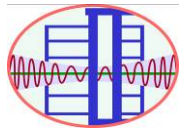

Figure 13. The orientation of the model fixed on the shaking table.

8. Loading protocols

All models will be tested simultaneously on the shaking table. The artificial earthquakes generated by the shaking table contain a broadband of sweeping excitation frequencies. The intensity of each artificial earthquake is represented by using the PGA. The PGA increases from one test to another. Figure 14 shows the two components of the displacement time histories of the artificial earthquake with the PGA equal to 250 gal.

- 8.1 There will be at most six tests, in which the PGAs are in the sequence of 250 gal, 400 gal, 500 gal, 600 gal, 700 gal, and 800 gal.
- 8.2 The teams whose models pass the test with the PGA equal to 400 gal, which is equivalent to an earthquake with the intensity equal to VI in Taiwan, will receive the Quake-Resistant Certificate.
- 8.3 Only the models passing the test with the PGA equal to 600 gal are qualified for ranking in this contest.

	2014 IDEERS Rules for Undergraduate Teams	IDEERS2014-V1
		2014-07-16
		15 of 19

8.4 The bidirectional time histories of the six artificial earthquakes are available on the IDEER's website. All teams are encouraged to download these data.

8.5 The mentioned directions are according to those specified in the lab. Figure 13 shows the directions and the orientation for mounting the models to the shaking table.

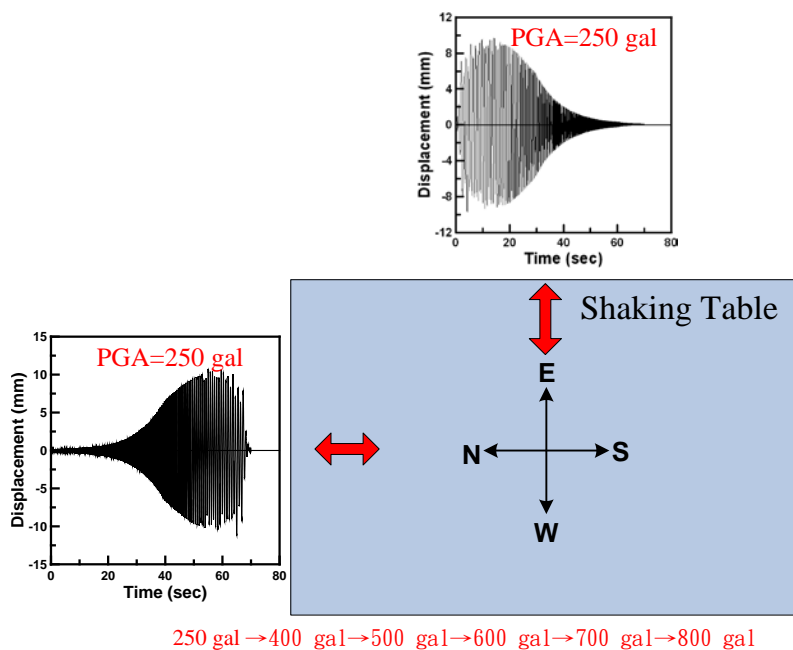

Figure 14. The E-W and N-S components of displacement time histories of the artificial earthquake with the PGA equal to 250 gal.

9. The failure criteria

A model will be judged to fail the test when the following conditions occur:

9.1 Any floor is unstable or collapsed.

9.2 Any mass block falls off or significantly dislocates.

9.3 The number of columns detached from the base board is larger than or equal to one half of the total number of columns.

9.4 The residual displacement of the inclined model, which is the horizontal distance measured from the original roof position to the final roof position, is greater than or equal to 10 cm.

9.5 The jury has the consensus of a model failing the test.

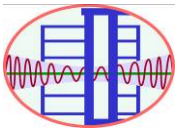
	2014 IDEERS Rules for Undergraduate Teams	IDEERS2014-V1
		2014-07-16
		16 of 19

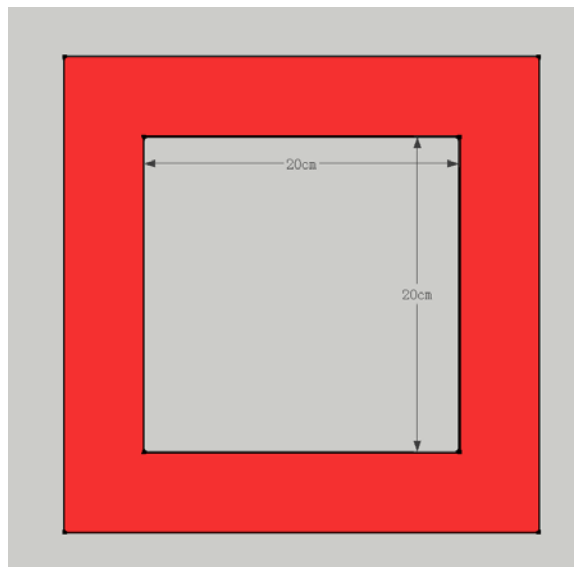

Figure 15. The shape of the check frame.

10. The check frame

A check frame shown as Figure 15 is provided to each team by the organizer. In order to make sure that the models are built within the allowable area, all teams are suggested to utilize the check frame by putting this frame through the models. Every horizontal cross section of the model should be within the opening of the check frame. The model violating this rule will be punished by adding 500 g penalty mass.

11. The poster

11.1 Poster: Each team must prepare an A4-size (29.7 cm L × 21 cm W) poster showing the design concept and creativity of the model. The poster may be displayed in a static or dynamic manner, but its maximum allowable demonstration space is 35 cm in height, 25 cm in width, and 25 cm in depth as shown in Figure 16. The materials for making the poster exhibition frame should be the wooden panel and wooden sticks that NCREE provides for the participants. Evaluation of the Best Poster Award will be based on the aforementioned facts. The affiliation of the team including the department and the university/college should be presented at the top of the poster. This poster is done before the contest is held.

11.2 Poster exhibition frame : Each team should paste the poster on the poster board, which is supported by using a frame. This frame is made of wooden sticks (Figure 17) and is done during the first day of this contest using the materials NCREE provides.

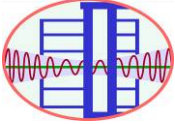
	2014 IDEERS Rules for Undergraduate Teams	IDEERS2014-V1
		2014-07-16
		17 of 19

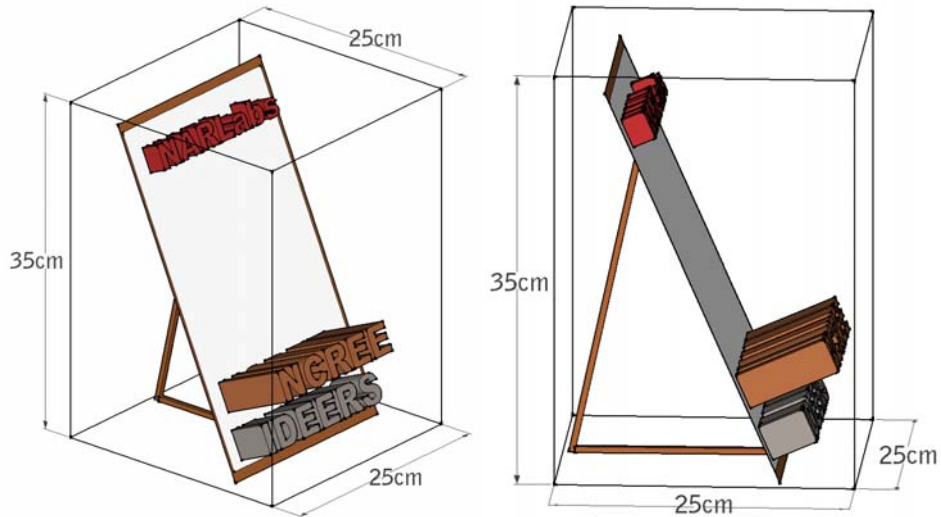

Figure 16. Allowable demonstration space for the poster

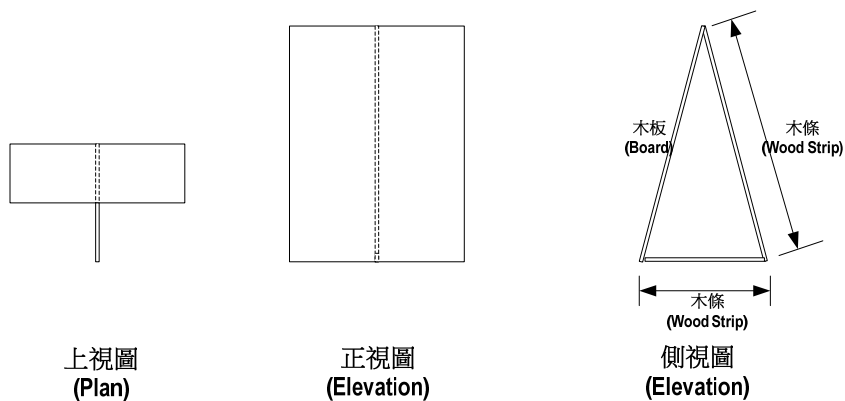
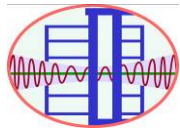

Figure 17. The poster exhibition frame.

12. The team flag

Each team must design a team flag, which is installed on the model during the first day of this contest. This flag may be drawn before or during this contest. All possible shapes of this flag are allowed. Nevertheless, the size of this flag should be no larger than that of a sheet of A6-size paper (14.4 cm L × 10.5 cm W, i.e., a quarter of an A4-size paper). This flag can be installed on the model by using any provided materials, such as the bamboo sticks.

	2014 IDEERS Rules for Undergraduate Teams	IDEERS2014-V1
		2014-07-16
		18 of 19

13. Model inspection

The period of the model inspection begins at the end of the model construction and ends at the start of the shaking table tests.

13.1 The procedures of the model inspection are:

(1) The host calls the team number. (2) The members of the team being called weigh the model. (3) The judges inspect the model and then fill in the inspection form. (4) The staffs take a picture of the model and the poster. (5) The team members place the model and the poster on the display table. On the second day, all competitors and judges vote models and posters for some special prizes. (6) Two team members mount the model onto the shaking table for the tests.

13.2 The items submitted to the judges for inspection are:

(1) the model, (2) the model inspection form, (3) the calculation sheet of the floor area, (4) the check frame and (5) the poster pasted on the exhibiting frame.

All of the abovementioned items are taken to the judges by two members of each team.

13.3 During the model inspection period, judges have the right to request the model to be modified or to make penalties to the model if the model violates the contest rules. During the two-day contest, jury has the right to re-inspect any models. The team, whose model needs to be re-inspected by the jury, cannot reject this request.

14. Special notices

14.1 In comparison with the contest rules adopted in previous years, there are significant modifications in this year's contest rules. All participants should read all contest rules in detail. The main modifications of this year's contest rules are:

14.1.1 There is no restriction on the allowable maximum number of wooden sticks fixed on the base board.

14.1.2 There is only a requirement on the minimum number of mass blocks installed (Rules 5.3), while the participating team has its free will whether additional mass blocks are favorable.

14.1.3 The way of fixing the base board onto the shaking table is to use the clamping strip. (Figure 18)

14.1.4 Due to the change of the way of fixing the base board onto the shaking table, the size of the base board is changed into 26 cm × 26 cm.

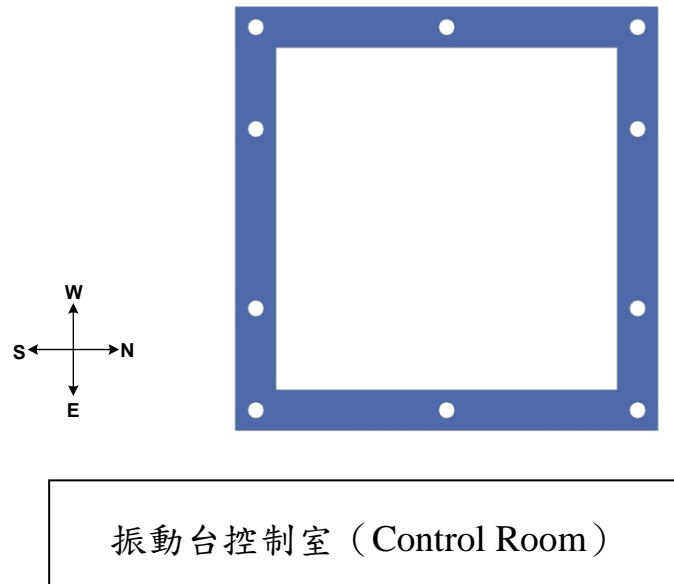

Figure 18. The clamping strip for fixing the base board.

- 14.2 In order to save the inspection time, each team should complete the model inspection form, the calculation sheets of the floor area and the number of mass blocks before submitting the model to the judges for inspection.
- 14.3 Each team must clean their working area and arrange the tools in order after completing their model. Otherwise, the team will be punished by adding a penalty weight equal to 500 g.

Check Table of 2014 IDEERS Undergraduate Teams

Team No.		School Name	
M_M (Mass of the Model)		g	Reviewer
M_B (Mass of the Base Board)		g	
M_P (Weight Penalty)		g	
$M_M - M_B + M_P =$		g	
1. Field cleanup & tools collation		Penalty (500g)	
<input type="checkbox"/> O.K. <input type="checkbox"/> N.G.			
2. Building range & board boundary clear width (≥ 3 cm)		Penalty (500g)	
cm			
3. Height ($55\text{cm} \leq H \leq 70\text{cm}$)		Penalty (200g)	
cm			
4. Total floor area ($1400 \leq A \leq 2800 \text{ cm}^2$)		Penalty (100g)	
cm			
5. Exterior & interior clearance of 1FL		Penalty (500g)	
<input type="checkbox"/> O.K. <input type="checkbox"/> N.G.			
6. Violation of mass block installation requirements		Penalty (50g/per Steel Block)	
blocks			
7. Clear height (1FL $\geq 12\text{cm}$; $8\text{cm} \leq \text{OTHER FLRS} \leq 10\text{cm}$)		Penalty (50g/cm)	
__FL	cm	g	
__FL	cm	g	
__FL	cm	g	
5FL	cm	g	
4FL	cm	g	
3FL	cm	g	
2FL	cm	g	
1FL	cm	g	
8. Exterior clearance ($\sum X_i / \sum L_i > 45\%$)		Penalty (10g/ 1%)	
	$\sum L_i$	$\sum X_i$	$\sum X_i / \sum L_i$
__FL			%
__FL			%
__FL			%
__FL			%
5FL			%
4FL			%
3FL			%
2FL			%
9. Interior clearance ($\geq 5\text{cm}$)		Penalty (100g/cm)	
__FL	cm	g	
__FL	cm	g	
__FL	cm	g	
__FL	cm	g	
5FL	cm	g	
4FL	cm	g	
3FL	cm	g	
2FL	cm	g	
10. Floor area (each floor)		Penalty (5g/cm ²)	
__FL	cm ²	$\geq 200\text{cm}^2$	g
__FL	cm ²	$\geq 200\text{cm}^2$	g
__FL	cm ²	$\geq 200\text{cm}^2$	g
__FL	cm ²	$\geq 200\text{cm}^2$	g
5FL	cm ²	$\geq 200\text{cm}^2$	g
4FL	cm ²	$\geq 300\text{cm}^2$	g
3FL	cm ²	$\geq 300\text{cm}^2$	g
2FL	cm ²	$\geq 300\text{cm}^2$	g
Total		cm ²	
Number of steel blocks of each floor		Weighting	Wi
__FL		x 3 =	
__FL		x 3 =	
__FL		x 3 =	
__FL		x 2 =	
5FL		x 2 =	
4FL		x 1 =	
3FL		x 1 =	
2FL		x 1 =	
Total		$\sum W_i =$	

Unit: Area: cm² Length&Height: cm Mass: gram